

ART 280

HYDROSTATIC PNEUMATIC
TYRED ROLLER
EU Stage IIIA / US EPA Tier 3



EASY WEIGHT CHANGES

Ammann's unique ballast adjustment and the air-on-the-run system make it easy to control machine weight and tyre pressure, the two main compaction factors. The modular, easy-load ballasting system enables weight to be adjusted from 9 tonnes to 28 tonnes in an hour – with the help of only a forklift. Brand new cab reduces sound and boosts operator comfort and safety. Improved serviceability keeps crews productive and maintenance costs to a minimum. The roller is powered by a EU Stage IIIA / US EPA Tier 3 Deutz engine with EGR and muffler.

PRODUCTIVITY

Ballasting system

Unique ballasting system offers wide range of weight, from 9 to 28 tons

Air-On-Run system

Central inflation system for easy control of tyre pressure

Front isostatic axles with oscillation

Higher stability and increased surface coverage and quality

ERGONOMICS

Cab design

Spacious cab with low sound levels and 170° rotating seat for all-day operator comfort

Control and information display integrated into steering wheel

Multifunctional display for intuitive machine control and overview, even with unskilled operator

Visibility

Perfect all-around machine visibility for safety on the jobsite

APPLICATIONS

- Medium and large jobsites
- Transport construction (municipal and town roads, motorways, airfields)
- Building construction (houses and industrial zones)

SERVICEABILITY

Accessible service points

Perfect access to service points

Ground access to service and maintenance points

Machine serviced from ground, enabling comfort

Design that enables daily maintenance

Easy and fast daily maintenance

MAXIMUM RECOMMENDED COMPACTED LIFT THICKNESS AT OPTIMAL WORKING CONDITIONS

	Sand / gravel	Mixed soils	Silt	Clay	Stabilisation	Asphalt
ART 280	280 mm (11 in)	240 mm (9.5 in)	180 mm (7 in)	150 mm (5.9 in)	180 mm (7 in)	140 mm (5.5 in)

AMMANN

TECHNICAL SPECIFICATIONS
 ART 280 HYDROSTATIC
 PNEUMATIC TYRED ROLLER
 EU Stage IIIA / US EPA Tier 3

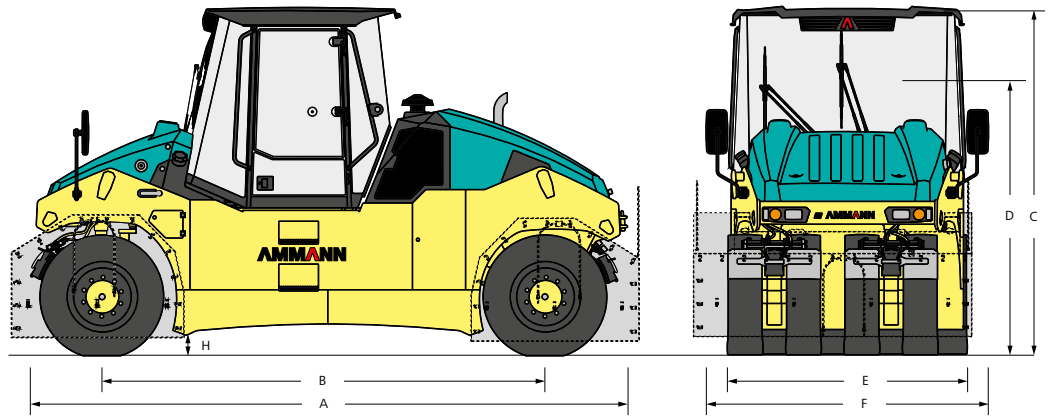

DIMENSIONS

A	MACHINE LENGTH	5040 mm (198.4 in)
A	MACHINE LENGTH (THERMAL APRONS)	5440 mm (214.2 in)
B	WHEELBASE	3800 mm (149.6 in)
C	MACHINE HEIGHT	3000 mm (118.1 in)
D	MACHINE HEIGHT (REMOVED ROPS)	-
E	WORKING WIDTH	2040 mm (80.3 in)
F	MACHINE WIDTH	2420 mm (95.3 in)
F	MACHINE WIDTH (THERMAL APRONS)	2440 mm (96.1 in)
H	GROUND CLEARANCE	180 mm (7.1 in)

WEIGHT & DRIVING CHARACTERISTICS

OPERATING WEIGHT	9700 kg (21 380 lb)
MAXIMUM WEIGHT	28 000 kg (61 730 lb)
MAX. TRANSPORT SPEED	19 km/h (11,8 MPH)
CLIMBING ABILITY	30%
TURNING RADIUS INNER (EDGE) LEFT	5080 mm (200 in)
TURNING RADIUS INNER (EDGE) RIGHT	5150 mm (202.8 in)
NUMBER OF FRONT WHEELS	4
NUMBER OF REAR WHEELS	4
SIZE OF TYRES	11.00 x 20"

MISCELLANEOUS

BRAKES OPERATING	Hydrostatic
BRAKES PARKING	Mechanical multiple-disc
BRAKES EMERGENCY	Mechanical multiple-disc
TYPE OF DRIVE	Hydrostatic
NUMBER OF DRIVEN WHEELS	4
OSCILLATION ANGLE	3°
ANGLE OF STEERING	32°
TYPE OF WATERING	Pressure
FUEL TANK CAPACITY	250 l (66 gal)
WATER FOR TYRE WATERING	400 l (105,7 gal)
VOLTAGE	24 V

ENGINE

MANUFACTURER	Deutz TCD3.6
POWER ACCORDING TO ISO 14396	100 kW (134 HP)
MAXIMUM TORQUE	500(369)/1600 Nm(ft lb)/rpm
ENGINE COMPLIES WITH EMISSION REGULATIONS	EU Stage IIIA / US EPA Tier 3
NUMBER OF CYLINDERS	4
COOLING SYSTEM OF ENGINE	Liquid



STANDARD EQUIPMENT

- CE conformity kit
- Open driver's platform with railing and protection against vandalism
- One driver's seat and steering wheel with integrated display
- 4 + 4 smooth diagonal tyres 18 PR
- Air-on-run tyre inflation system
- Isostatic oscillating front axle
- Hydrostatic rear axle drive
- Work lights

OPTIONAL EQUIPMENT

- Cab ventilated and heated
- Air condition for Cab version
- Water ballast option (1.8 t)
- Additional ballast up to 28 t
- Thermal aprons
- Edge cutter
- Radial tyres